

Installation Guide

VIBNE802

WT-V/WT-V FC Accumulator tanks



Thermia AB is not liable or bound by warranty if these instructions are not adhered to during installation or service.

The English language is used for the original instructions.
Other languages are a translation of the original instructions.
(Directive 2006/42/EC)

© Copyright Thermia AB

Table of Contents

1	Getting started	4
1.1	Getting started	4
2	Model specifications	5
2.1	WT-V	5
2.2	WT-V FC (Front Connection)	9

1 Getting started

1.1 Getting started

Installation

The accumulator tank should stand on a solid surface and be leveled with assistance from the setscrews underneath the tank (not fitted on all models). The tank models that come without setscrews can be leveled with assistance of a shim. This must be done before the tank is connected to the pipes and filled with water. The setscrews can be adjusted down to a maximum of 25mm. Connections not in use must be plugged appropriately. During water filling, condensed water may emerge on the outside of the tank. This will result in water underneath the tank, on the floor. This will cease when the tank is heated. There must be a floor drain in the same room.

To temporarily remove the insulation, for instance if there is a narrow passage to fit the tank through, see the below instructions (not applicable to all models). All the screws holding the insulation in place is of Torx 10 type.

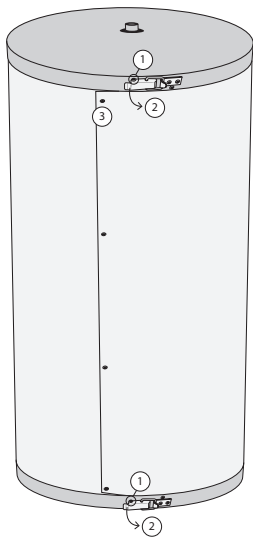

1. Start by removing the screws that holds the locks in place. At the top and bottom.
2. Flip the locks.
3. Remove the screws all the way down. The side is also fitted with a velcro on the inside.
4. Put the insulation back in the reversed order.

Adjust the setscrews according to the measures below.

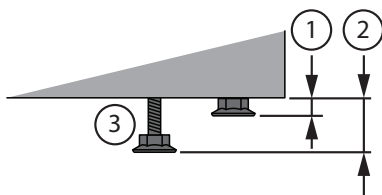

1. Foot length is 14mm.
2. Maximum length between floor and tank is 39mm, including foot.
3. Maximum screw length is 25mm, excluding foot.

Commissioning

Start by filling the tank, then pressurize it. Continue to fill the radiator system (the enclosed water). The working pressure may not exceed the test pressure (4,3 or 8,6 bars, gauge). A safety valve with releasing pressure of that of the test pressure must always be installed.

Maintenance

Check the safety valve annually by manually opening and closing the valve handle and making sure that water is released. Check annually all connections for eventual leakage (also peripheral installations, i.e. a heat pump, etc).

Electric installation

- The electrical installation must be performed by an authorised installer and follow applicable norms and regulations.
- When selecting electrical equipment, it must be selected with approved materials and enclosure class.

Disassembling the product

When disassembling the product, applicable laws and regulations must be observed. Contact your installer for more information.

2 Model specifications

2.1 WT-V

Technical data

WT-V	Unit	100	200	300
Storage volume V	litres	102	204	293
Test pressure	bar	4,3		
Working pressure	bar	3		
Max. temperature	°C	100		
Weight	kg	40	68	91
Standing loss S	W	60	68	78
Energy efficiency class	-	C		

Dimensions

WT-V	Unit	100	200	300
Height	mm	1558	1153	1564
Dimensions	mm	Ø380	601 x 600	635 x 600

2.1.2 WT-V 200

Connections

- 1 Expansion/Venting (DN25 int.)
- 2 Connections (DN32 x 4 int.)
- 3 Temperature sensor (2x)
- 4 Drainage valve (DN15)
- 5 Teamperature sensor pipe (Ø7 int.)
- 6 Diffuser
- 7 Connection (DN50)

Technical data

Storage volume V	204 litres
Test pressure	4,3 bar
Working pressure	3 bar
Max. temperature	100 °C
Weight	68 kg
Standing loss S	68 W
Energy efficiency class	C

Dimensions

Height (mm)	1153
Diameter (mm)	601 x 600

Required ceiling height for tilting: 1280 mm

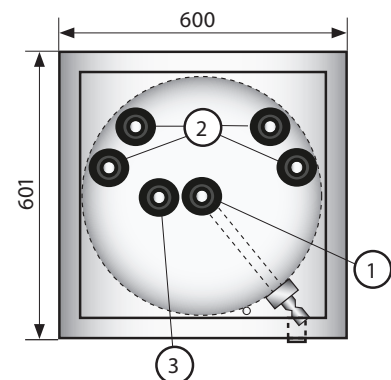
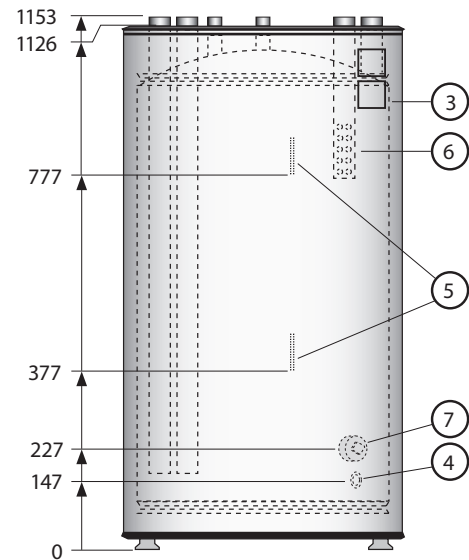

2.1.3 WT-V 300

Connections

- 1 Expansion/Venting (DN25)
- 2 Connections (DN32 x 4)
- 3 Temperature sensor conn. (DN20)
- 4 Drainage valve (DN15)
- 5 Teamperature sensor pipe (Ø7 x 5 int.)
- 6 Immersion heater conn. (DN50)
- 7 Diffuser (DN32)
- 8 Temperature sensor (2x)

Technical data

Storage volume V	293 litres
Test pressure	4,3 bar
Working pressure	3 bar
Max. temperature	100 °C
Weight	91 kg
Standing loss S	78 W
Energy efficiency class	C

Dimensions

Height (mm)	1564
Diameter (mm)	635 x 600

Required ceiling height for tilting: 1665 mm

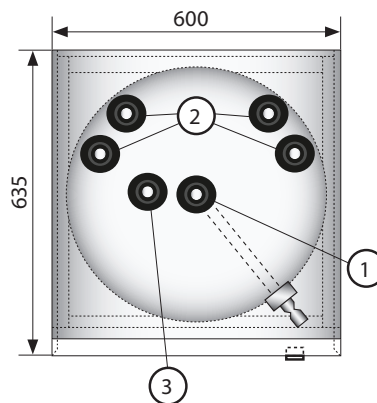
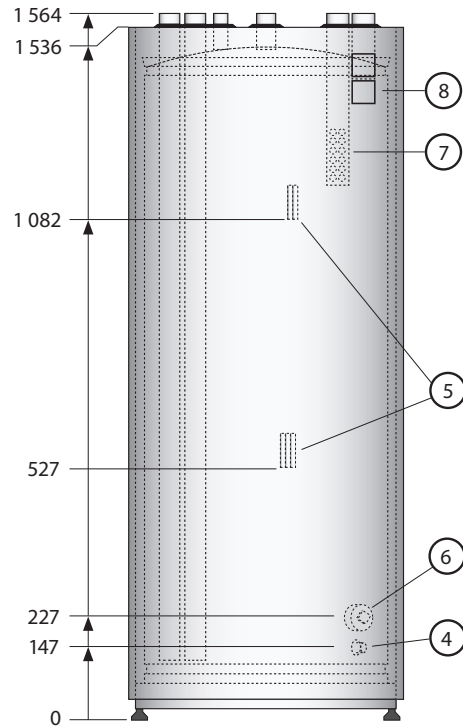

2.2 WT-V FC (Front Connection)

Technical data

WT-V 500 FC	Unit	500 FC (3Bar)	500 FC (6Bar)	500 FC DN80 (3Bar)	500 FC DN80 (6Bar)
Storage volume V	litres	477	503	477	503
Working pressure	bar	3	6	3	6
Test pressure	bar	4,3	8,6	4,3	8,6
Max. temperature	°C	100			
Weight	kg	94	117	97	120
Standing loss S	W	104	104	104	104
Energy efficiency class	-	C			
Height	mm	1765	1788	1765	1788
Dimensions	mm	Ø840	Ø840	Ø840	Ø840

WT-V 750 FC	Unit	750 FC (3Bar)	750 FC (6Bar)	750 FC DN80 (3Bar)	750 FC DN80 (6Bar)
Storage volume V	litres	721	676	721	676
Working pressure	bar	3	6	3	6
Test pressure	bar	4,3	8,6	4,3	8,6
Max. temperature	°C	100			
Weight	kg	114	135	117	138
Standing loss S	W	127	127	127	127
Energy efficiency class	-	C			
Height	mm	1825	1837	1825	1837
Dimensions	mm	Ø960	Ø950	Ø960	Ø950

WT-V 1000 FC	Unit	1000 FC (3Bar)	1000 FC (6Bar)	1000 FC DN80 (3Bar)	1000 FC DN80 (6Bar)
Storage volume V	litres	971	907	971	907
Working pressure	bar	3	6	3	6
Test pressure	bar	4,3	8,6	4,3	8,6
Max. temperature	°C	100			
Weight	kg	173	166	176	169
Standing loss S	W	130	130	130	135
Energy efficiency class	-	C			
Height	mm	1947	1900	1947	1900
Dimensions	mm	Ø1090	Ø1050	Ø1090	Ø1050

2.2.1 WT-V 500 FC (3Bar)

Connections

- 1 Venting (DN32)
- 2 Heat source (DN50, x4)
- 3 Temperature sensor (DN20, x2)
- 4 Immersion heater (DN50)
- 5 Drain tap/Temperature sensor (DN20)

Technical data

Storage volume V	477 litres
Working pressure	3 bar
Test pressure	4,3 bar
Max. temperature	100 °C
Weight	94 kg
Standing loss S	104 W
Energy efficiency class	C

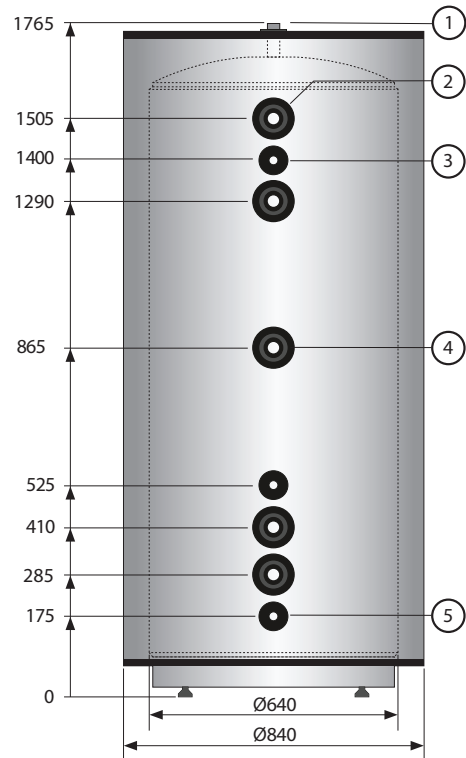

Dimensions

Height (mm)	1765
Diameter (mm)	Ø840
Diameter without insulation (mm)	Ø640

Required ceiling height for tilting: 1900 mm

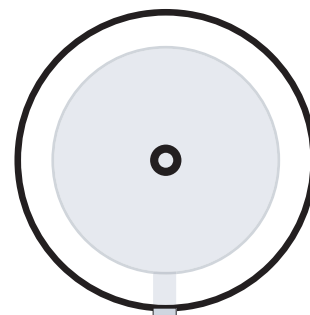

2.2.2 WT-V 500 FC (6Bar)

Connections

- 1 Venting (DN32)
- 2 Heat source (DN50, x4)
- 3 Temperature sensor (DN20, x2)
- 4 Immersion heater (DN50)
- 5 Drain tap/Temperature sensor (DN20)

Technical data

Storage volume V	503 litres
Working pressure	6 bar
Test pressure	8,6 bar
Max. temperature	100 °C
Weight	117 kg
Standing loss S	104 W
Energy efficiency class	C

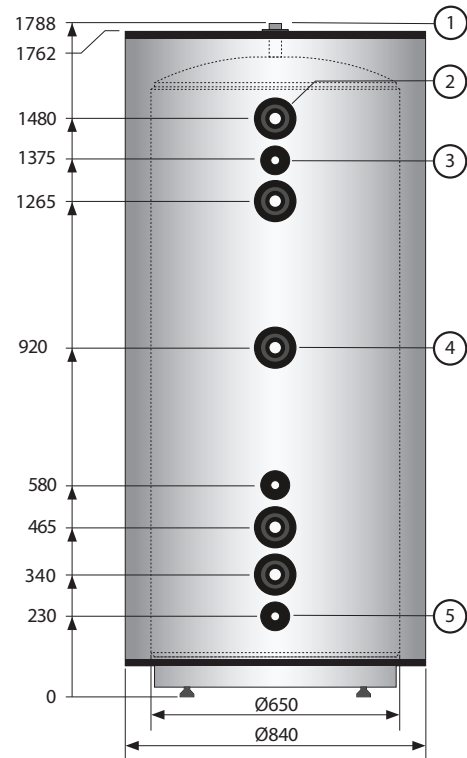

Dimensions

Height (mm)	1788
Diameter (mm)	Ø840
Diameter without insulation (mm)	Ø640

Required ceiling height for tilting: 1900 mm

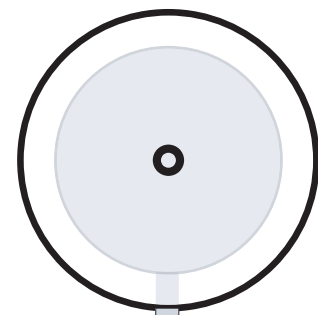

2.2.3 WT-V 500 FC DN80 (3Bar)

Connections

- 1 Venting (DN32)
- 2 Heat source (DN80, x4)
- 3 Temperature sensor (DN20, x2)
- 4 Immersion heater (DN50)
- 5 Drain tap/Temperature sensor (DN20)

Technical data

Storage volume V	477 litres
Working pressure	3 bar
Test pressure	4,3 bar
Max. temperature	100 °C
Weight	97 kg
Standing loss S	104 W
Energy efficiency class	C

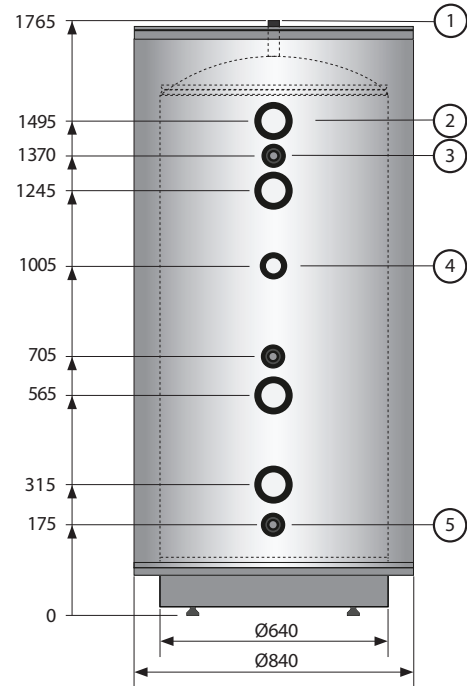

Dimensions

Height (mm)	1765
Diameter (mm)	Ø840
Diameter without insulation (mm)	Ø640

Required ceiling height for tilting: 1900 mm

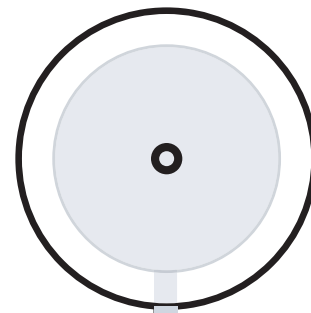

2.2.4 WT-V 500 FC DN80 (6Bar)

Connections

- 1 Venting (DN32)
- 2 Heat source (DN80, x4)
- 3 Temperature sensor (DN20, x2)
- 4 Immersion heater (DN50)
- 5 Drain tap/Temperature sensor (DN20)

Technical data

Storage volume V	503 litres
Working pressure	6 bar
Test pressure	8,6 bar
Max. temperature	100 °C
Weight	120 kg
Standing loss S	104 W
Energy efficiency class	C

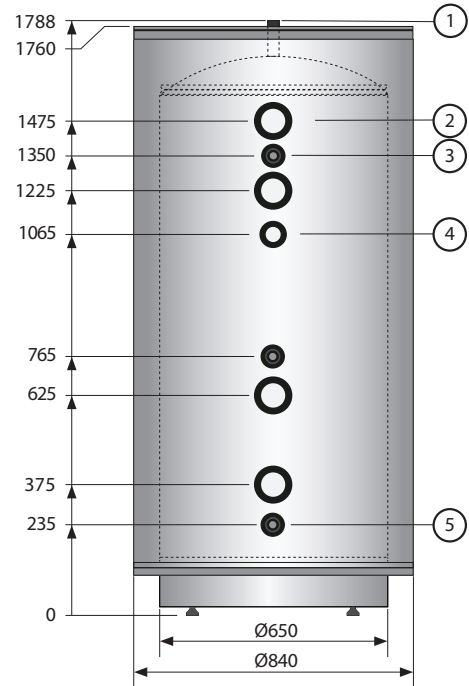

Dimensions

Height (mm)	1786
Diameter (mm)	Ø840
Diameter without insulation (mm)	Ø650

Required ceiling height for tilting: 1900 mm

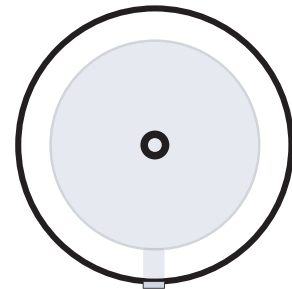

2.2.5 WT-V 750 FC (3Bar)

Connections

- 1 Venting (DN32)
- 2 Heat source (DN50 x 4)
- 3 Temperature sensor (DN20 x 2)
- 4 Immersion heater (DN50)
- 5 Drain tap/Temperature sensor (DN20)

Technical data

Storage volume V	721 litres
Working pressure	3 bar
Test pressure	4,3 bar
Max. temperature	100 °C
Weight	114 kg
Standing loss S	127 W
Energy efficiency class	C

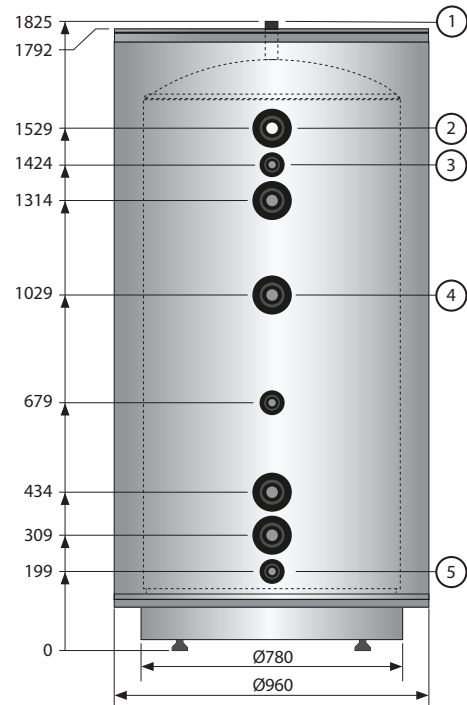

Dimensions

Height (mm)	1825
Diameter (mm)	Ø960
Diameter without insulation (mm)	Ø780

Required ceiling height for tilting: 2000 mm

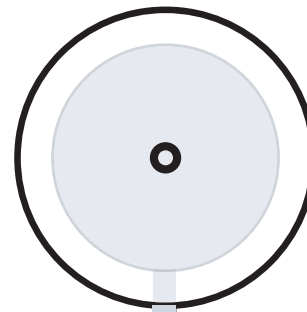

2.2.6 WT-V 750 FC (6Bar)

Connections

- 1 Venting (DN32)
- 2 Heat source (DN50 x 5)
- 3 Temperature sensor (DN20 x 2)
- 4 Immersion heater (DN50)
- 5 Drain tap/Temperature sensor (DN20)

Technical data

Storage volume V	676 litres
Working pressure	6 bar
Test pressure	8,6 bar
Max. temperature	100 °C
Weight	135 kg
Standing loss S	127 W
Energy efficiency class	C

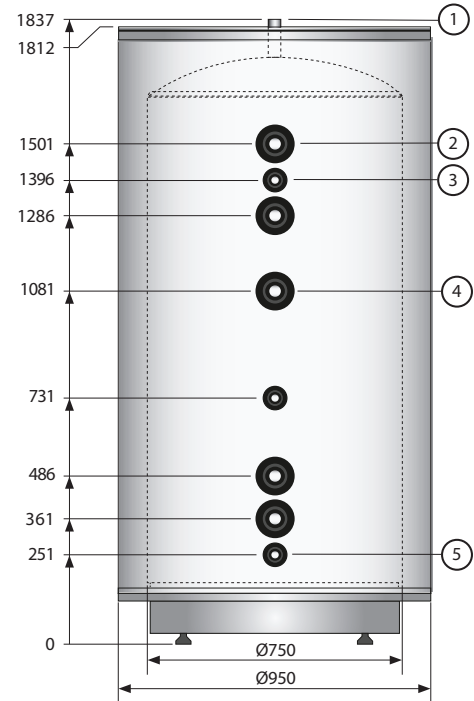

Dimensions

Height (mm)	1837
Diameter (mm)	Ø950
Diameter without insulation (mm)	Ø750

Required ceiling height for tilting: 2000 mm

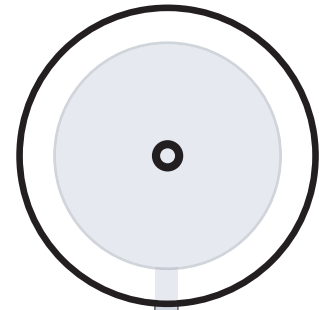

2.2.7 WT-V 750 FC DN80 (3Bar)

Connections

- 1 Venting (DN32)
- 2 Heat source (DN80 x 4)
- 3 Temperature sensor (DN20 x 2)
- 4 Immersion heater (DN50)
- 5 Drain tap/Temperature sensor (DN20)

Technical data

Storage volume V	721 litres
Working pressure	3 bar
Test pressure	4,3 bar
Max. temperature	100 °C
Weight	117 kg
Standing loss S	127 W
Energy efficiency class	C

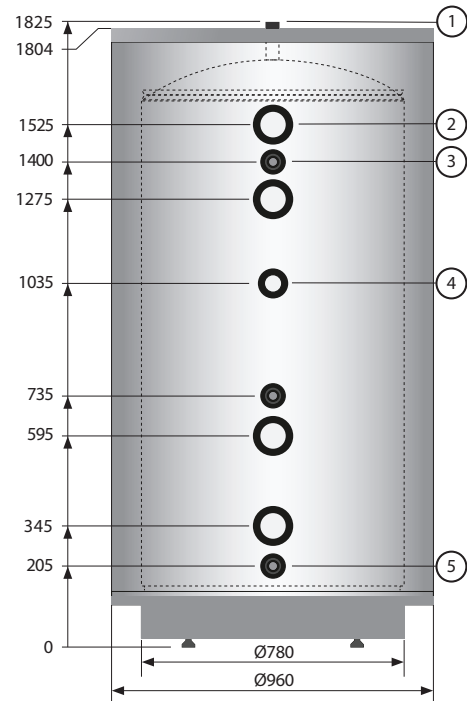

Dimensions

Height (mm)	1825
Diameter (mm)	Ø960
Diameter without insulation (mm)	Ø780

Required ceiling height for tilting: 2000 mm

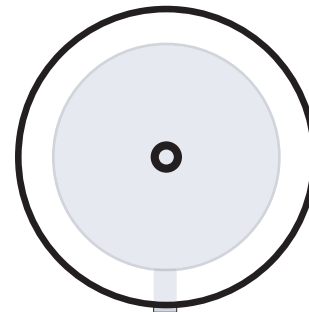

2.2.8 WT-V 750 FC DN80 (6Bar)

Connections

- 1 Venting (DN32)
- 2 Heat source (DN80 x 4)
- 3 Temperature sensor (DN20 x 2)
- 4 Immersion heater (DN50)
- 5 Drain tap/Temperature sensor (DN20)

Technical data

Storage volume V	676 litres
Working pressure	6 bar
Test pressure	8,6 bar
Max. temperature	100 °C
Weight	138 kg
Standing loss S	127 W
Energy efficiency class	C

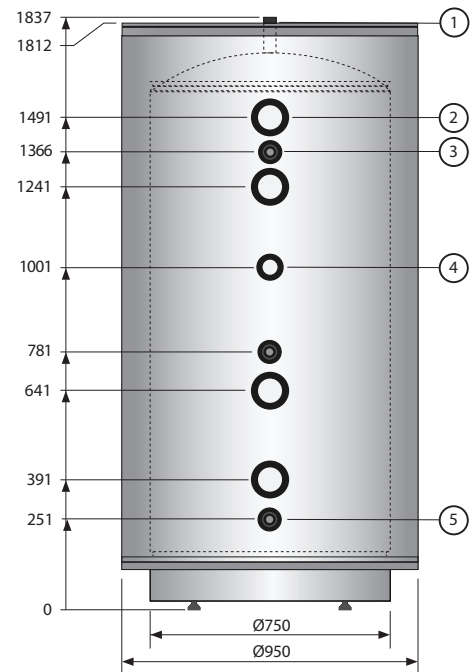

Dimensions

Height (mm)	1837
Diameter (mm)	Ø950
Diameter without insulation (mm)	Ø780

Required ceiling height for tilting: 2000 mm

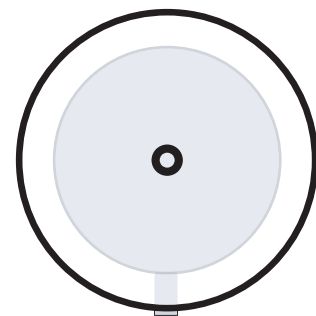

2.2.9 WT-V 1000 FC (3Bar)

Connections

- 1 Venting (DN32)
- 2 Heat source (DN50 x 4)
- 3 Temperature sensor (DN20 x 2)
- 4 Immersion heater (DN50)
- 5 Drain tap/Temperature sensor (DN20)

Technical data

Storage volume V	971 litres
Working pressure	3 bar
Test pressure	4,3 bar
Max. temperature	100 °C
Weight	173 kg
Standing loss S	130 W
Energy efficiency class	C

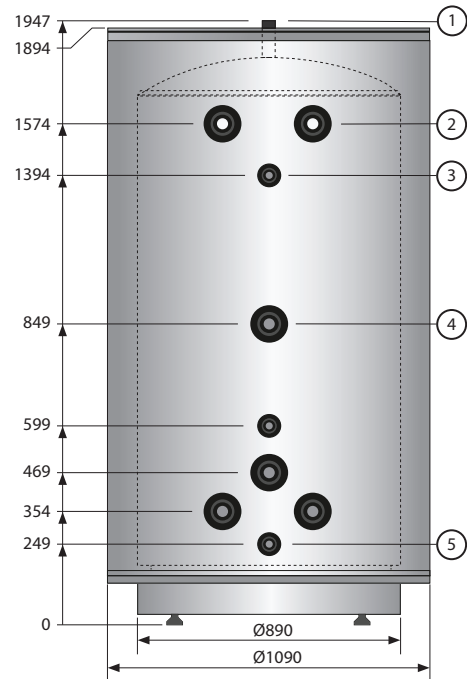

Dimensions

Height (mm)	1947
Diameter (mm)	Ø1090
Diameter without insulation (mm)	Ø890

Required ceiling height for tilting: 2120 mm

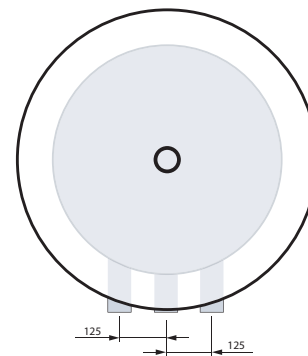

2.2.10 WT-V 1000 FC (6Bar)

Connections

- 1 Venting (DN32)
- 2 Heat source (DN50 x 4)
- 3 Temperature sensor (DN20 x 2)
- 4 Immersion heater (DN50)
- 5 Drain tap/Temperature sensor (DN20)

Technical data

Storage volume V	907 litres
Working pressure	6 bar
Test pressure	8,6 bar
Max. temperature	100 °C
Weight	166 kg
Standing loss S	130 W
Energy efficiency class	C

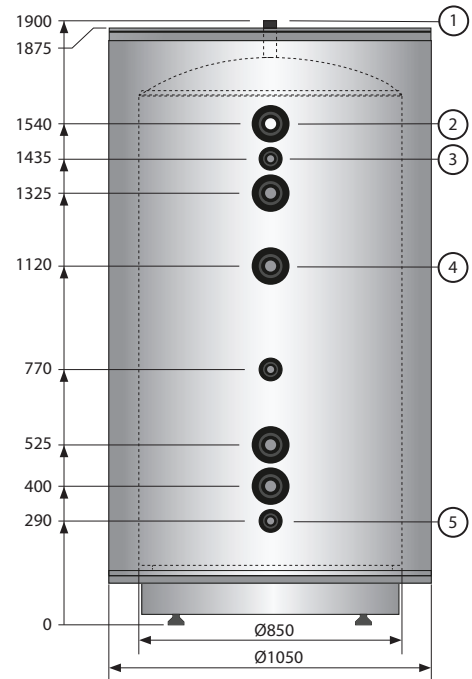

Dimensions

Height (mm)	1900
Diameter (mm)	Ø1050
Diameter without insulation (mm)	Ø850

Required ceiling height for tilting: 2090 mm

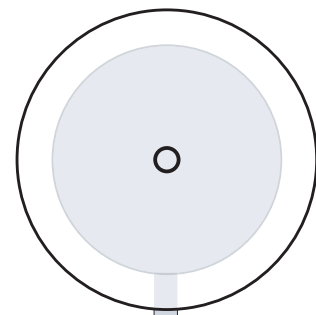

2.2.11 WT-V 1000 FC DN80 (3Bar)

Connections

- 1 Venting (DN32)
- 2 Heat source (DN80, x4)
- 3 Temperature sensor (DN20, x2)
- 4 Immersion heater (DN50)
- 5 Drain tap/Temperature sensor (DN20)

Technical data

Storage volume V	971 litres
Working pressure	3 bar
Test pressure	4,3 bar
Max. temperature	100 °C
Weight	176 kg
Standing loss S	130 W
Energy efficiency class	C

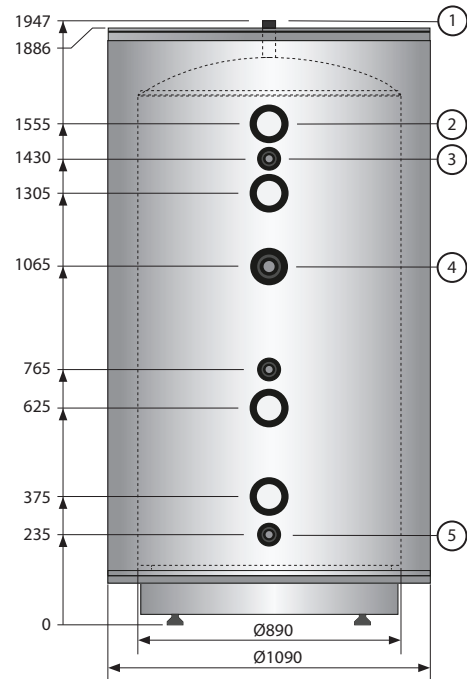

Dimensions

Height (mm)	1947
Diameter (mm)	Ø1090
Diameter without insulation (mm)	Ø890

Required ceiling height for tilting: 2120 mm

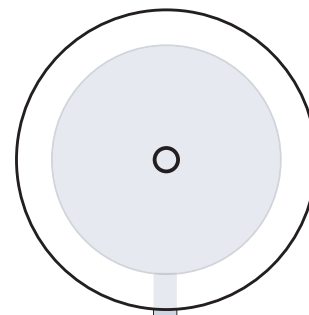

2.2.12 WT-V 1000 FC DN80 (6Bar)

Connections

- 1 Venting (DN32)
- 2 Heat source (DN80, x4)
- 3 Temperature sensor (DN20, x2)
- 4 Immersion heater (DN50)
- 5 Drain tap/Temperature sensor (DN20)

Technical data

Storage volume V	907 litres
Working pressure	6 bar
Test pressure	8,6 bar
Max. temperature	100 °C
Weight	169 kg
Standing loss S	130 W
Energy efficiency class	C

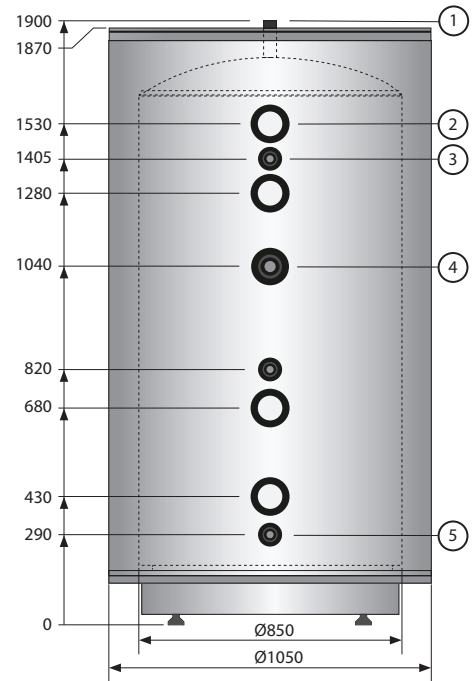

Dimensions

Height (mm)	1900
Diameter (mm)	Ø1050
Diameter without insulation (mm)	Ø850

Required ceiling height for tilting: 2090 mm

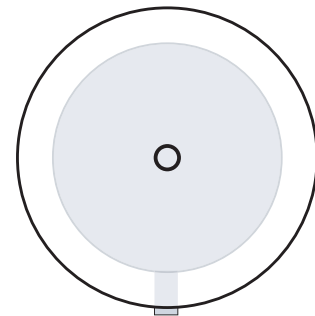





Thermia AB
Box 950
SE 671 29 ARVIKA
Phone +46 570 81300
E-mail: info@thermia.com
Internet: www.thermia.com

Thermia can accept no responsibility for possible errors in catalogues, brochures and other printed material. Thermia reserves the right to alter its products without notice. This also applies to products already on order provided that such alterations can be made without subsequential changes being necessary in specifications already agreed. All trademarks in this material are property of the respective companies. Thermia AB and the Thermia AB logotype are trademarks of Thermia AB. All rights reserved.
