

**Installation Guide**

# **WT-C FC Accumulator tanks**



Thermia AB is not liable or bound by warranty if these instructions are not adhered to during installation or service.

The English language is used for the original instructions.  
Other languages are a translation of the original instructions.  
(Directive 2006/42/EC)

© Copyright Thermia AB



---

## Table of Contents

---

<b>1</b>	<b>Getting started</b> .....	<b>4</b>
1.1	Getting started .....	4
<b>2</b>	<b>Model specifications</b> .....	<b>5</b>
2.1	WT-C FC (Front Connection) .....	5

## 1 Getting started

### 1.1 Getting started

#### Installation

The accumulator tank should stand on a solid surface and be leveled with assistance from the setscrews underneath the tank (not fitted on all models). The tank models that come without setscrews can be leveled with assistance of a shim. This must be done before the tank is connected to the pipes and filled with water. See picture below for adjusting the setscrews. Connections not in use must be plugged appropriately. During water filling, condensed water may emerge on the outside of the tank. This will result in water underneath the tank, on the floor. This will cease when the tank is heated. There must be a floor drain in the same room.

To temporarily remove the insulation, for instance if there is a narrow passage to fit the tank through, see the below instructions (not applicable to all models). All the screws holding the insulation in place is of Torx 10 type.

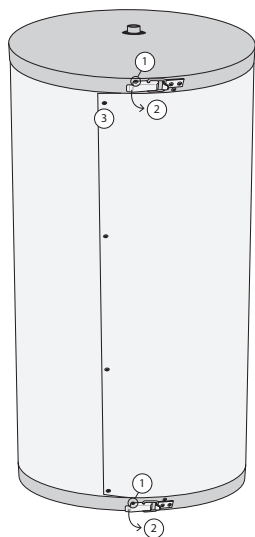

1. Start by removing the screws that holds the locks in place. At the top and bottom.
2. Flip the locks.
3. Remove the screws all the way down. The side is also fitted with a velcro on the inside.
4. Put the insulation back in the reversed order.

Adjust the setscrews according to the measures below.

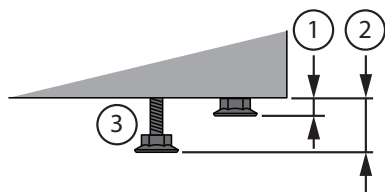

1. Foot length is 14mm.
2. Maximum length between floor and tank is 39mm, including foot.
3. Maximum screw length is 25mm, excluding foot.

#### Commissioning

Start by filling the tank, then pressurize it. Continue to fill the radiator system (the enclosed water). The working pressure may not exceed the test pressure (4,3 or 8,6 bars, gauge). A safety valve with releasing pressure of that of the test pressure must always be installed.

#### Maintenance

Check the safety valve annually by manually opening and closing the valve handle and making sure that water is released. Check annually all connections for eventual leakage (also peripheral installations, i.e. a heat pump, etc).

#### Electric installation

- The electrical installation must be performed by an authorised installer and follow applicable norms and regulations.
- When selecting electrical equipment, it must be selected with approved materials and enclosure class.

#### Disassembling the product

When disassembling the product, applicable laws and regulations must be observed. Contact your installer for more information.

## 2 Model specifications

### 2.1 WT-C FC (Front Connection)

#### Technical data

WT-C FC	Unit	500 FC (3Bar)	500 FC (6Bar)	750 FC (3Bar)	750 FC (6Bar)	1000 FC (3Bar)	1000 FC (6Bar)
Total volume	litres	477	503	721	676	971	907
Storage volume V	litres	466	492	704,5	659,5	949	885
Total coil volume	litres	11	11	16,5	16,5	22	22
Coil length	m	4x12	4x12	6x12	6x12	8x12	8x12
Coil surface (per coil)	m <sup>2</sup>	3					
Working pressure	Bar	3	6	3	6	3	6
Test pressure	Bar	4,3	8,6	4,3	8,6	4,3	8,6
Max pressure, coil	Bar	10					
Max. temperature	°C	100					
Max. immersion heater length	mm	700	710	840	810	950	910
Weight	kg	142	164	187	208	270	262
Standing loss S	W	104	104	127	127	130	135
Energy efficiency class	-	C					
Height	mm	1765	1788	1830	1837	1927	1900
Dimensions	mm	Ø840	Ø840	Ø960	Ø950	Ø1090	Ø1050
Dimensions without insulation	mm	Ø640	Ø650	Ø780	Ø750	Ø890	Ø850
Depth, including coil connections	mm	932	939	1065	1049	1186	1149

## 2.1.1 WT-C 500 FC (3 bar)

### Connections

- 1 Venting (DN32)
- 2 Heat source (DN50, x4)
- 3 Tap water coil (2x12m, Ø22mm)
- 4 Temperature sensor (DN20, x2)
- 5 Heat source (DN32)
- 6 Heat source/Immersion heater (DN50)
- 7 Preheat coil/Tap water (2x12m, Ø22mm)
- 8 Drain tap/Temperature sensor (DN20)

### Technical data

Total volume	477 litres
Storage volume V	466 litres
Total coil volume	11 litres
Coil surface (per coil)	3 m <sup>2</sup>
Working pressure	3 bar
Test pressure	4,3 bar
Max. pressure, coil	10 bar
Max. temperature	100 °C
Max. immersion heater length	700 mm
Weight	142 kg
Standing loss S	104 W
Energy efficiency class	C

### Dimensions (mm)

Height	1765
Diameter	Ø840
Diameter without insulation	Ø640
Depth, including coil connections	932

Required ceiling height for tilting: 1900 mm

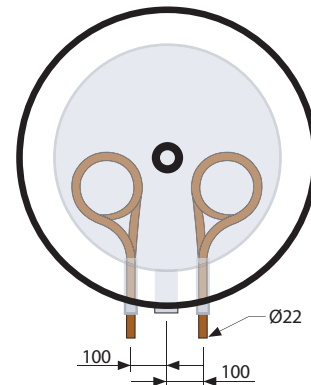
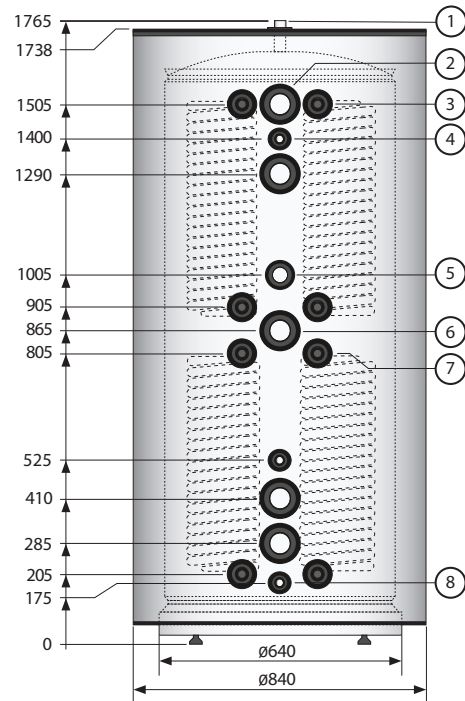

## 2.1.2 WT-C 500 FC (6 bar)

### Connections

- 1 Venting (DN32)
- 2 Heat source (DN50, x4)
- 3 Tap water coil (2x12m, Ø22mm)
- 4 Temperature sensor (DN20, x2)
- 5 Heat source (DN32)
- 6 Heat source/Immersion heater (DN50)
- 7 Preheat coil/Tap water (2x12m, Ø22mm)
- 8 Drain tap/Temperature sensor (DN20)

### Technical data

Total volume	503 litres
Storage volume V	492 litres
Total coil volume	11 litres
Coil surface (per coil)	3 m <sup>2</sup>
Working pressure	6 bar
Test pressure	8,6 bar
Max. pressure, coil	10 bar
Max. temperature	100 °C
Max. immersion heater length	710 mm
Weight	164 kg
Standing loss S	104 W
Energy efficiency class	C

### Dimensions (mm)

Height	1788
Diameter	Ø840
Diameter without insulation	Ø650
Depth, including coil connections	939

Required ceiling height for tilting: 1900 mm

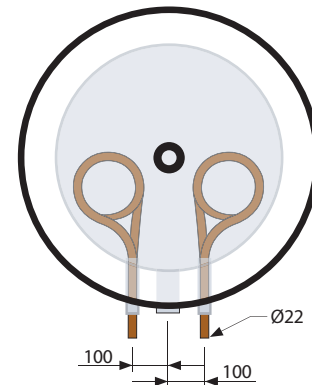
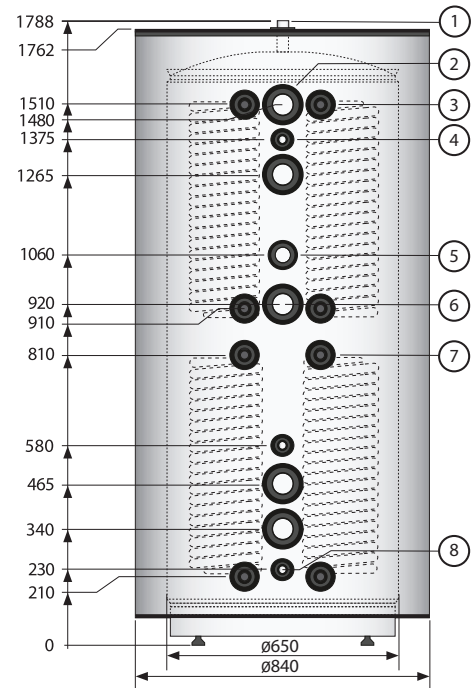

## 2.1.3 WT-C 750 FC (3 bar)

### Connections

- 1 Venting (DN32)
- 2 Heat source (DN50, x4)
- 3 Tap water coil (3x12m, Ø22mm)
- 4 Temperature sensor (DN20, x2)
- 5 Heat source (DN32)
- 6 Heat source/Immersion heater (DN50)
- 7 Preheat coil/Tap water (3x12m, Ø22mm)
- 8 Drain tap/Temperature sensor (DN20)

### Technical data

Total volume	721 litres
Storage volume V	704,5 litres
Total coil volume	16,5 litres
Coil surface (per coil)	3 m <sup>2</sup>
Working pressure	3 bar
Test pressure	4,3 bar
Max. pressure, coil	10 bar
Max. temperature	100 °C
Max. immersion heater length	840 mm
Weight	187 kg
Standing loss S	127 W
Energy efficiency class	C

### Dimensions (mm)

Height	1830
Diameter	Ø960
Diameter without insulation	Ø780
Depth, including coil connections	1065

Required ceiling height for tilting: 2000 mm

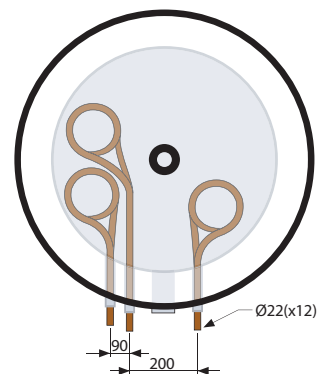
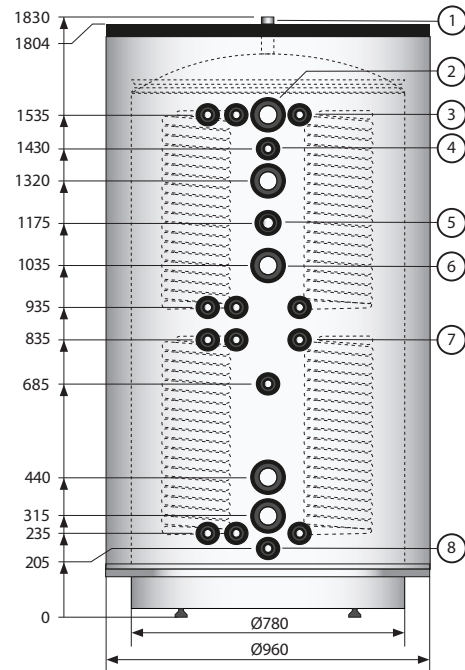

## 2.1.4 WT-C 750 FC (6 bar)

### Connections

- 1 Venting (DN32)
- 2 Heat source (DN50, x4)
- 3 Tap water coil (3x12m, Ø22mm)
- 4 Temperature sensor (DN20, x2)
- 5 Heat source (DN32)
- 6 Heat source/Immersion heater (DN50)
- 7 Preheat coil/Tap water (3x12m, Ø22mm)
- 8 Drain tap/Temperature sensor (DN20)

### Technical data

Total volume	676 litres
Storage volume V	659,5 litres
Total coil volume	16,5 litres
Coil surface (per coil)	3 m <sup>2</sup>
Working pressure	6 bar
Test pressure	8,6 bar
Max. pressure, coil	10 bar
Max. temperature	100 °C
Max. immersion heater length	810 mm
Weight	208 kg
Standing loss S	127 W
Energy efficiency class	C

### Dimensions (mm)

Height	1837
Diameter	Ø950
Diameter without insulation	Ø750
Depth, including coil connections	1049

Required ceiling height for tilting: 2000 mm

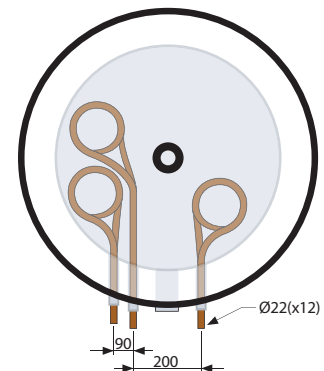
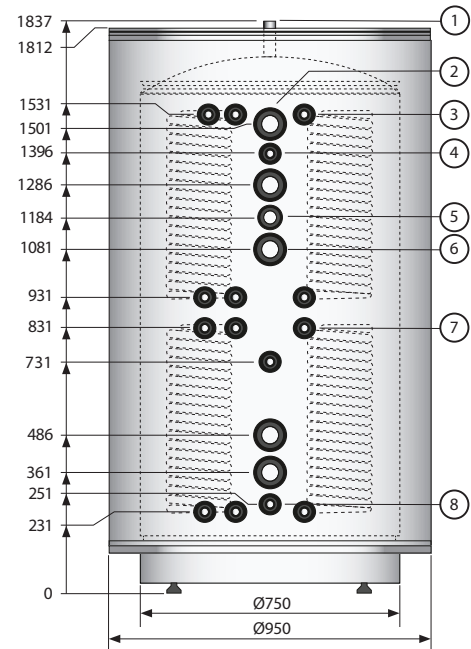

## 2.1.5 WT-C 1000 FC (3 bar)

### Connections

- 1 Venting (DN32)
- 2 Heat source (DN50, x4)
- 3 Tap water coil (4x12m, Ø22mm)
- 4 Temperature sensor (DN20, x2)
- 5 Heat source (DN32)
- 6 Heat source/Immersion heater (DN50)
- 7 Preheat coil/Tap water (4x12m, Ø22mm)
- 8 Drain tap/Temperature sensor (DN20)

### Technical data

Total volume	971 litres
Storage volume V	949 litres
Total coil volume	22 litres
Coil surface (per coil)	3 m <sup>2</sup>
Working pressure	3 bar
Test pressure	4,3 bar
Max. pressure, coil	10 bar
Max. temperature	100 °C
Weight	270 kg
Standing loss S	130 W
Energy efficiency class	C

### Dimensions (mm)

Height	1927
Diameter	Ø1090
Diameter without insulation	Ø890
Depth, including coil connections	1186

Required ceiling height for tilting: 2120 mm

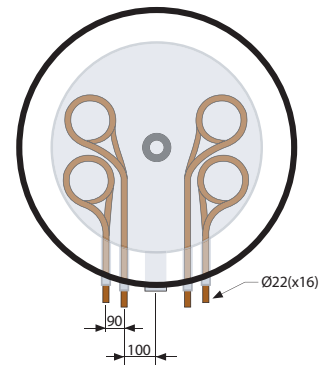
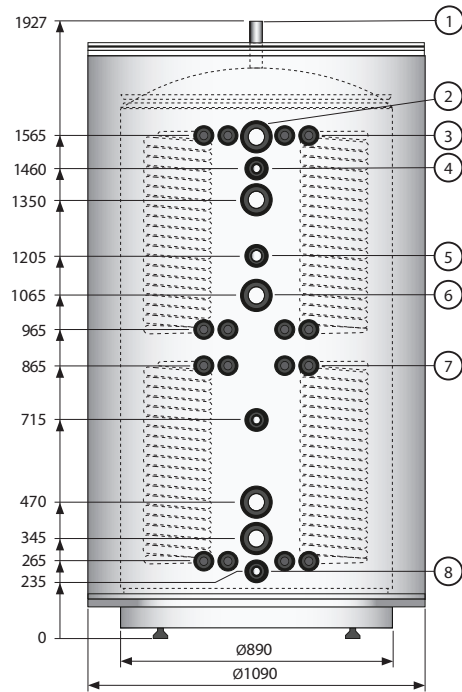

## 2.1.6 WT-C 1000 FC (6 bar)

### Connections

- 1 Venting (DN32)
- 2 Heat source (DN50, x4)
- 3 Tap water coil (4x12m, Ø22mm)
- 4 Temperature sensor (DN20, x2)
- 5 Heat source (DN32)
- 6 Heat source/Immersion heater (DN50)
- 7 Preheat coil/Tap water (4x12m, Ø22mm)
- 8 Drain tap/Temperature sensor (DN20)

### Technical data

Total volume	907 litres
Storage volume V	885 litres
Total coil volume	22 litres
Coil surface (per coil)	3 m <sup>2</sup>
Working pressure	6 bar
Test pressure	8,6 bar
Max. pressure, coil	10 bar
Max. temperature	100 °C
Max. immersion heater length	910 mm
Weight	262 kg
Standing loss S	135 W
Energy efficiency class	C

### Dimensions (mm)

Height	1900
Diameter	Ø1050
Diameter without insulation	Ø850
Depth, including coil connections	1149

Required ceiling height for tilting: 2090 mm

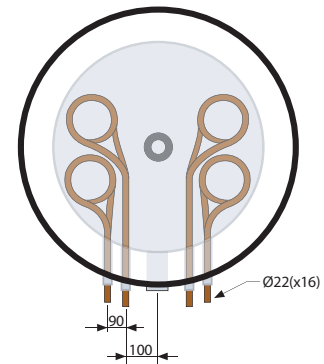
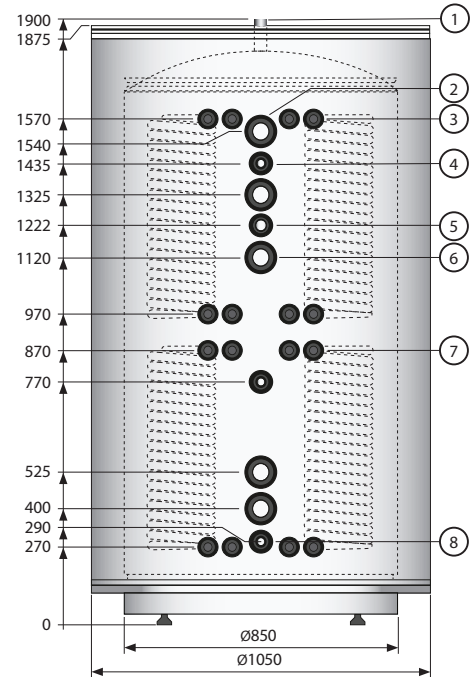











Thermia AB  
Box 950  
SE 671 29 ARVIKA  
Phone +46 570 81300  
E-mail: [info@thermia.com](mailto:info@thermia.com)  
Internet: [www.thermia.com](http://www.thermia.com)

---

Thermia can accept no responsibility for possible errors in catalogues, brochures and other printed material. Thermia reserves the right to alter its products without notice. This also applies to products already on order provided that such alterations can be made without subsequential changes being necessary in specifications already agreed. All trademarks in this material are property of the respective companies. Thermia AB and the Thermia AB logotype are trademarks of Thermia AB. All rights reserved.

---